

XC6 – ESMini™ COM Carrier Board for 3.5" PCs

- **1 ESMini™ computer-on-module slot**
- **2 Fast Ethernet , 4 USB 2.0, 1 UART**
- **DVI-I, audio I/O, TTY**
- **PCI Express® Mini Card slot and SIM card holder**
- **USB Flash disk slot**
- **microSD™ card holder**
- **SATA for external hard disk on board**
- **-40 to +85°C screened**

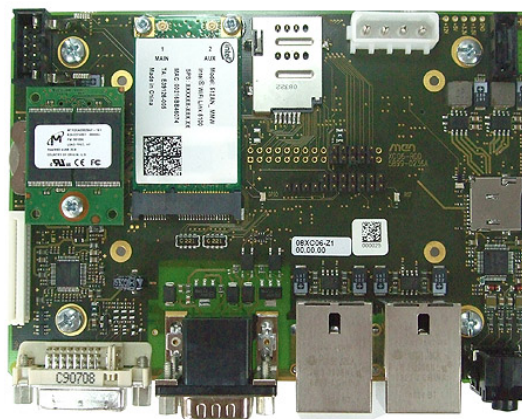

The XC6 is an ESMini™ carrier that can be used together with any type of ESMini™ module. It provides a PCI Express® Mini Card slot with SIM card holder for wireless applications. A USB Flash disk slot and a microSD™ card slot as well as a SATA connector for an external hard disk allow a further extension of the storage capacity. As graphics the XC6 provides a

DVI-I connector. As I/O the XC6 offers 2 Fast Ethernet, 4 USB host ports (one also configurable as a client), audio in and out, a configurable RS232/RS422/RS485 interface on a 9-pin D-Sub connector, a TTY interface for a modem, eight GPIO lines with +5V level and 16 GPIO lines with 3.3V level. The I/O of the XC6 can be extended by connecting an SA-Adapter™ to the +5V GPIO connector, e.g. for IBIS or CAN bus functionality.

Its dimensions correspond to a 3.5" PC.

Diagram

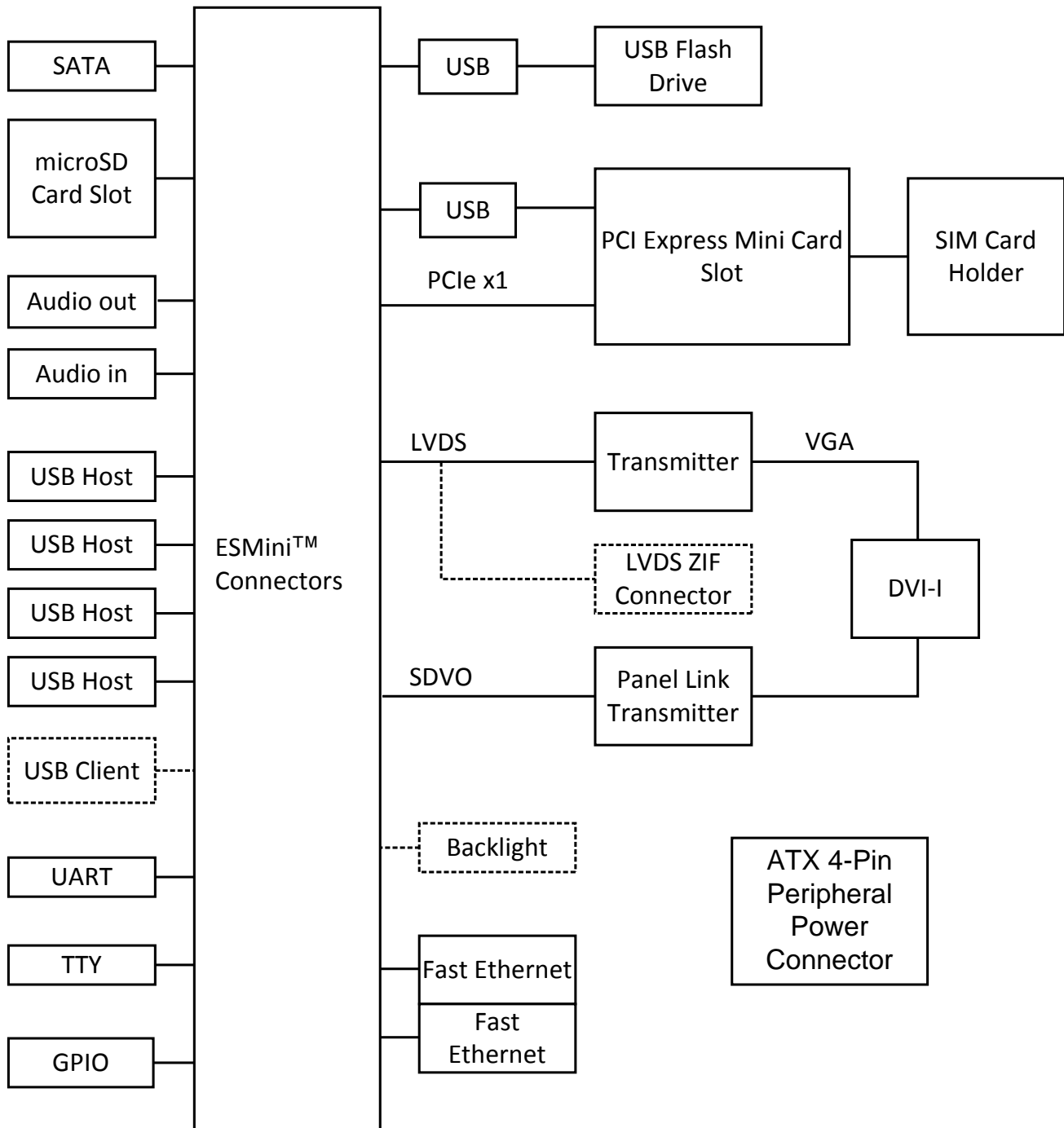

Legend

 Option

Technical Data

ESMini™ Carrier Card	<ul style="list-style-type: none"> ■ One ESMini™ slot ■ J1 and J2 assembled
Memory	<ul style="list-style-type: none"> ■ One SATA connector ■ One USB Flash disk slot <ul style="list-style-type: none"> □ Via one USB onboard connector ■ One microSD™ card slot
Graphics	<ul style="list-style-type: none"> ■ One DVI-I connector <ul style="list-style-type: none"> □ Analog VGA signals via LVDS interface
I/O	<ul style="list-style-type: none"> ■ Four USB 2.0 host connectors, one optionally usable as client ■ 10/100Base-T Ethernet <ul style="list-style-type: none"> □ Two interfaces on RJ45 connectors ■ Audio <ul style="list-style-type: none"> □ Audio in □ Audio out □ Via 3.5 mm jack ■ RS232/RS422/RS485 <ul style="list-style-type: none"> □ One interface via 9-pin D-Sub connector □ Configurable via software ■ TTY <ul style="list-style-type: none"> □ Max. transfer rate 4800 bit/sec □ Active or passive □ Electrically isolated ■ GPIO <ul style="list-style-type: none"> □ 8 lines on a 10-pin connector (5 V level, for connection of an SA-Adapter™) □ 16 lines on an 18-pin connector (3.3 V level)
One PCI Express® Mini Card slot	<ul style="list-style-type: none"> ■ With SIM card slot ■ Via one PCI Express® x1 links and one USB port
Miscellaneous	<ul style="list-style-type: none"> ■ Goldcap ■ Battery holder ■ Power button signal on pin header ■ Reset in/out on pin header
Electrical Specifications	<ul style="list-style-type: none"> ■ Supply voltage/power consumption: <ul style="list-style-type: none"> □ ATX standard power supply via 4-pin connector □ +5 V, 2.1 A max. □ +12 V (12 V only for LVDS backlight), (depends on the display) 0.7 A with SHARP LQ121S1LG61 (12.1" / 800x600) with full brightness □ Power supply cable should have a cross section of at least 1.5 mm² ■ MTBF: 683,499 h @ 40°C according to IEC/TR 62380 (RDF 2000)
Mechanical Specifications	<ul style="list-style-type: none"> ■ Dimensions: 146x102 mm ■ Weight: 142 g (without ESMini™ module)
Environmental Specifications	<ul style="list-style-type: none"> ■ Temperature range (operation): <ul style="list-style-type: none"> □ -40..+85°C (screened) □ Airflow depending on ESMini™ module ■ Temperature range (storage): -40..+85°C ■ Relative humidity (operation): max. 95% non-condensing ■ Relative humidity (storage): max. 95% non-condensing ■ Altitude: -300 m to +2,000 m ■ Bump: 10 g/16 ms ■ Conformal coating on request
Safety	<ul style="list-style-type: none"> ■ PCB manufactured with a flammability rating of 94V-0 by UL recognized manufacturers

Configuration & Options

Standard Configurations

Article No.	Interfaces
08XC06-01	1x TTY, 1x RS232, 1x DVI-I, 1x Audio I/O 4x USB2.0, 2x Fast Ethernet

Options

Graphics	<ul style="list-style-type: none"> ■ One LVDS ZIF connector <ul style="list-style-type: none"> □ For direct connection of an LVDS display □ Instead of VGA signals on the DVI-I connector ■ One LVDS backlight 10-pin connector
I/O	<ul style="list-style-type: none"> ■ One USB client port instead of one of the host ports ■ Connection of SA-Adapter™ on 10-pin GPIO connector (e.g. with IBIS or CAN bus functionality)

Please note that some of these options may only be available for large volumes. Please ask our sales staff for more information.

Ordering Information

Standard XC6 Models	08XC06-01	Carrier board for ESMINI™: 1x TTY, 1x RS232, 1x DVI-I, 1x Audio I/O, 4x USB2.0, 2x Fast Ethernet, USB Flash slot, PCI Express® Mini Card socket, SIM card holder, microSD™ card socket, 8x GPIOs, -40°C..+85°C screened
Related Hardware	15MM01-00	Intel® Atom™ Z510, 1.1 GHz, 512MB RAM, 1 Fast Ethernet, 1 CAN, -40..+85°C Tcase screened
	15MM01-01	Intel® Atom™ Z530, 1.6 GHz, 1GB RAM, 2 Fast Ethernet, 2 CAN, -25..+85°C Tcase screened
	15MM02-00	Intel® Atom™ E680T, 1.6 GHz, 1GB DDR2 DRAM, 2 Gigabit Ethernet, 1 CAN, 4 COM, with J1 and J2, -40..+85°C with qualified components, with cover and frame
	15PX01-00	GLONASS & GPS PCI Express® MiniCard (full size), 3-axis Gyro sensor, -40..+85°C with qualified components
Miscellaneous Accessories	0712-0019	Standard ATX PSU, 350 W, 0..+40°C
Documentation	20APPN004	Application Note: How to make a USB stick bootable
	20XC06-ER	XC6 Errata
	20XC06-00	XC6 User Manual

Contact Information

Germany

MEN Mikro Elektronik GmbH
Neuwieder Straße 3-7
90411 Nuremberg
Phone +49-911-99 33 5-0
Fax +49-911-99 33 5-901

info@men.de
www.men.de

France

MEN Mikro Elektronik SA
18, rue René Cassin
ZA de la Châtelaine
74240 Gaillard
Phone +33 (0) 450-955-312
Fax +33 (0) 450-955-211

info@men-france.fr
www.men-france.fr

USA

MEN Micro Inc.
860 Penllyn Blue Bell Pike
Blue Bell, PA 19422
Phone (215) 542-9575
Fax (215) 542-9577

sales@menmicro.com
www.menmicro.com

The date of issue stated in this data sheet refers to the Technical Data only. Changes in ordering information given herein do not affect the date of issue. All brand or product names are trademarks or registered trademarks of their respective holders.

MEN is not responsible for the results of any actions taken on the basis of information in the publication, nor for any error in or omission from the publication.

MEN expressly disclaims all and any liability and responsibility to any person, whether a reader of the publication or not, in respect of anything, and of the consequences of anything, done or omitted to be done by any such person in reliance, whether wholly or partially, on the whole or any part of the contents of the publication.

The correct function of MEN products in mission-critical and life-critical applications is limited to the environmental specification given for each product in the technical user manual. The correct function of MEN products under extended environmental conditions is limited to the individual requirement specification and subsequent validation documents for each product for the applicable use case and has to be agreed upon in writing by MEN and the customer. Should the customer purchase or use MEN products for any unintended or unauthorized application, the customer shall indemnify and hold MEN and its officers, employees, subsidiaries, affiliates, and distributors harmless against all claims, costs, damages, and expenses, and reasonable attorney fees arising out of, directly or indirectly, any claim or personal injury or death associated with such unintended or unauthorized use, even if such claim alleges that MEN was negligent regarding the design or manufacture of the part.

In no case is MEN liable for the correct function of the technical installation where MEN products are a part of.

Copyright © 2014 MEN Mikro Elektronik GmbH. All rights reserved.