

**EPS-12002L** EPS-12002L Compact 12+2 Port Managed Ethernet Switch



**FEATURES**

- Rugged Ethernet switch for vehicle and other harsh environment applications
- 12 gigabit Ethernet ports for twisted pair connections
- 2 1/2.5/5/10G SFP+ sockets for fiber or copper transceivers
- All ports feature non-blocking wire-speed performance
- Layer 2+ switching and Layer 3 routing software available
- IEEE 1588 PTP support available
- Software customization and branding available
- Rugged design with latching connectors and -40 to +85°C operating temperature
- 5.3 x 2.2" / 136 x 55mm
- Heat sink and heat spreader thermal options



**EPS-12002L switch with cooling solution removed to show detail**



**EPS-12002L switch end view, cooling solution removed**



### **EPS-12002L-HSK with integrated heat sink**

The EPS-12002L is a compact managed rugged Ethernet switch based on Diamond's **EPSM-10GX** Ethernet switch module. The switch consists of the EPSM-10GX module mounted on a carrier board that provides power, magnetics, and connectors, along with a heat sink or heat spreader. EPS-12002L provides 12 10/100/1000Mbps copper ports and 2 1/2.5/5/10Gbps SFP+ sockets for fiber or copper transceivers. EPS-12002L is ideal for vehicle and industrial applications requiring a small form factor with gigabit Ethernet switching and fiber connectivity support.

Two software packages are available, Layer 2+ switching and Layer 3 routing/switching. All software features are manageable via a GUI web interface accessible over any port, as well as with a command language accessed via a built-in RS-232 port.

EPS-12002L is designed specifically to meet the challenges of vehicle and other rugged environments, with its -40/+85°C operating temperature range, latching I/O connectors, and MIL-STD-202G shock/vibration resistance. A 5-36V input power supply provides compatibility with a range of industrial and vehicle power supplies.

#### **◆ Embedded Software**

Two software packages are available: Layer 2+ switching and Layer 3 routing/switching. In addition, IEEE-1588 precision time protocol support is available with a minor modification to install a precision clock circuit on the board. All software features are manageable via a GUI web interface accessible over any port, as well as with a command language accessed via a built-in RS-232 port. Customer branding is available to put your logo / color scheme / part numbers on the GUI and serial interface.

The table below shows some of the more popular features available. For a complete list of features available in each software package, [click here](#).

#### Layer 2+ software highlights include the following:

- 8K MAC addresses and 4K VLANs (IEEE 802.1Q)
- 8K IPv4 and IPv6 multicast group support
- Jumbo frame support at all speeds
- Flexible link aggregation support based on Layer-2 through Layer-4 information (IEEE 802.3ad)
- Multicast and broadcast storm control, as well as flooding control
- Rapid Spanning Tree protocol (RSTP) and MSTP
- Multiple protocol support: IEEE 802.1d, IEEE 802.1w, IEEE 802.1s, and IEEE 802.1X
- 8 priorities and 8 QoS queues per port with scheduling

#### Layer3 software additional highlights:

- Hardware- and software-based IPv6 L3 static routing
- RFC 2328 OSPFv2 dynamic routing

IEEE 1588 precision time protocol (PTP)  
 RADIUS accounting  
 Port and Queue policers

**DIAMOND SYSTEMS** EPSM-10G™ 26-Port Gigabit Ethernet Switch  
 Software version 1.0.0

Configuration  
 ▶ System  
 ▶ Green Ethernet  
 - LED  
 - Port Power Savings  
 - Thermal Protection  
 ▶ Ports  
 ▶ Security  
 ▶ Switch  
 ▶ Network  
 ▶ AAA  
 ▶ Aggregation  
 - Loop Protection  
 ▶ Spanning Tree  
 ▶ IPMC  
 ▶ LLDP  
 - MAC Table  
 - VLANs  
 ▶ Private VLANs  
 ▶ QoS  
 - Mirroring  
 Monitor  
 ▶ System  
 ▶ Green Ethernet  
 - Thermal Protection  
 ▶ Ports  
 - State  
 - Traffic Overview  
 - QoS Statistics  
 - QCL Status  
 - Detailed Statistics  
 ▶ Security  
 ▶ Aggregation  
 - Loop Protection  
 ▶ Spanning Tree  
 ▶ IPMC  
 ▶ LLDP  
 - MAC Table  
 ▶ VLANs  
 ▶ Diagnostics  
 ▶ Maintenance

**Port State Overview** Auto-refresh  Refresh

RJ45 ports			
SFP ports			
State	Disabled	Down	Link

**◆ Cable Kit**

Cable Kit for EPS-12000-CM: 3x Quad Gigabit Ethernet cables, Power cable, Serial cable



CK-EPS12000 includes the following cables:

No.	Qty	Cable	Description	Drawing
1	1	6981050	Serial Cable, 1x3 2mm to DB9M	<a href="#">Show</a>
2	1	6981507	Power Cable, IPD 2x2 to Leads, 20AV	<a href="#">Show</a>
3	3	6981508	Ethernet Cable, 4 Ports, JST 32 Pin	<a href="#">Show</a>

**◆ Block Diagram**

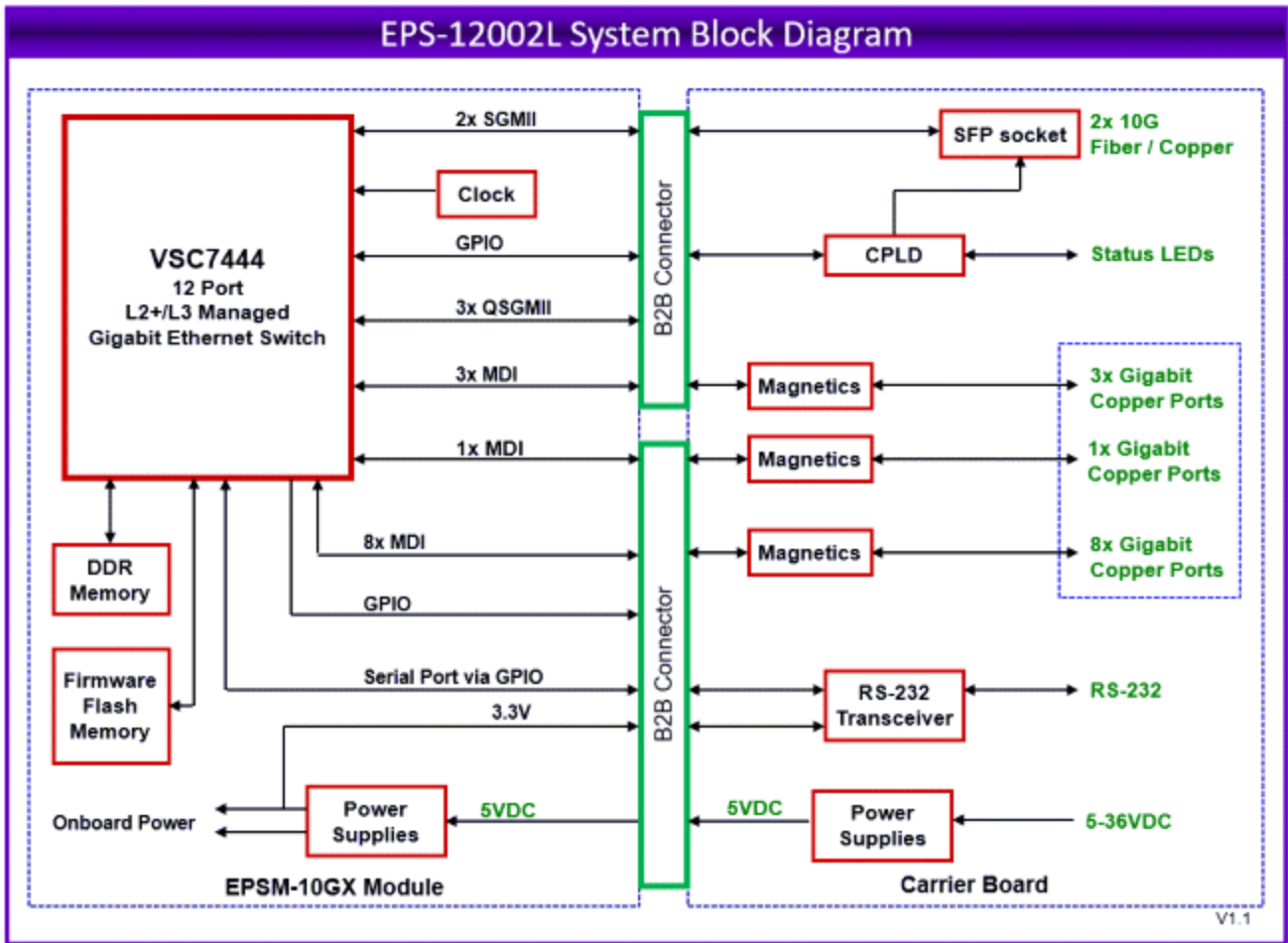

◆ **Ordering Information**

◆ **Models and Accessories**

EPIS-12002L

**available models:**

<b>EPS-12002-HSK</b>	12 1Gbe Ports + 2 1/2.5/5/10Gbe SFP+ sockets, Layer 2 software, socket headers, heat sink	By Request
<b>EPS-12002L-HSK</b>	12 1Gbe Ports + 2 1/2.5/5/10Gbe SFP+ sockets, Layer 2 software, heat sink	Available
<b>EPS-12002L-HSP</b>	12 1Gbe Ports + 2 1/2.5/5/10Gbe SFP+ sockets, Layer 2 software, heat spreader	Available
<b>EPS-12002L-HSK-L3</b>	12 1Gbe Ports + 2 1/2.5/5/10Gbe SFP+ sockets, Layer 3 routing software, heat sink	By Request
<b>EPS-12002L-HSP-L3</b>	12 1Gbe Ports + 2 1/2.5/5/10Gbe SFP+ sockets, Layer 3 routing software, heat spreader	By Request

Please [login](#) or [signup](#) for an online quote request.

**Cables and accessories**

**available models:**

- [CK-EPS12000](#) Cable kit for EPS-12000-CM
- [6981050](#) Serial Cable, 1x3 2mm to DB9M
- [6981507](#) Power Cable, IPD 2x2 to Leads, 20AV
- [6981508](#) Ethernet Cable, 4 Ports, JST 32 Pin

Please [login](#) or [signup](#) for an online quote request.

[www.diamondsystems.com](http://www.diamondsystems.com) | [Sunnyvale, California USA](#) | [+1-650-810-2500](tel:+16508102500) | [sales@diamondsystems.com](mailto:sales@diamondsystems.com)