

IC-INT-VPX3d/e

Intel® XEON (Broadwell-DE SoC) SBC

OpenVPX

The **IC-INT-VPX3d/e** is a powerful OpenVPX 3U Single Board Computer (SBC) based on the Broadwell-DE processor – 14nm High Performance Chip of Intel's Low Power Spectrum.

Combined with IC's **ComEth 4580a** 10 Gigabit Ethernet router or hybrid **ComEth4410a** switch (PCIe & Ethernet) and other IC's Processor/FPGAs boards with IC's software / Firmware libraries, the **IC-INT-VPX3d/e** is the key building block of the next High Performance Embedded Computing systems (HPEC).

The **IC-INT-VPX3d/e** like any IC Intel® board, is delivered with IC's own UEFI. This capability to master Boot firmware allows Interface Concept to implement specific functions or services for secured and accurate power-up sequences.



RoHS ✓

Description

The **IC-INT-VPX3d/e** is a 3U VPX SBC which can act as a System or non-System Controller module in a VPX platform.

The **IC-INT-VPX3d** provides:

- ▶ two 10Giga Ethernet ports for Data Plane on P1A/P1B,
- ▶ one PCIe x4 port for Extension Plane on P1C,
- ▶ two GigaEthernet ports for Control Plane.

The PCIe port for Extension Plane supports Non-transparent Bridging (NTB) allowing Processor to Processor Communications.

To maintain compatibility with **IC-INT-VPX3a/b** boards, the **IC-INT-VPX3e** version provides:

- ▶ two PCIe x4 ports for Data Plane on P1A/P1B,
- ▶ two 10Giga Ethernet (KR) ports for Extension Plane on P1C,
- ▶ two GigaEthernet ports for Control Plane.

The **IC-INT-VPX3d/e** also takes advantage of the media capabilities of the Intel SoC to provide a set of serial interfaces (USB and SATA ports), GPIOs and additional PCIe ports on P2.

The board features one SATA Solid State Disk for storage.

The **IC-INT-VPX3d/e** implements a FPGA interfaced with the SoC (PCIe x4) to add Core Functions, for which IC provides a variety of IPs (additional communications interfaces, GPIOs, video...) and performs the integration of specified customer services.

As an option, an XMC slot is also available to support Legacy mezzanines or custom designs.

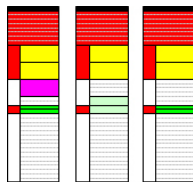

The **IC-INT-VPX3d/e** is compliant at least with the following **OpenVPX** Slot profiles (VITA 65):

Main features

Processor Unit

- ▶ One Intel® Xeon® Processor D-15xx
- ▶ Two banks of DDR4 with ECC (up to 8GB / Bank)
- ▶ Boot flash memory
- ▶ External independent RTC with supercap backup
- ▶ Thermal/voltage monitoring sensors
- ▶ One SATA NAND SSD (up to 16GB)

Communication subsystem

IC-INT-VPX3d

- ▶ 2 * 10Gbe ports (2 * KX4 or 2 * KR - factory setting)
- ▶ 2 * PCIe x4 ports (one on P1C , one on P2)

IC-INT-VPX3e

- ▶ 3 * PCIe x4 ports (two on P1A/P1B , one on P2)
- ▶ 2 * 10Gbe ports (2 * KR)

- ▶ 2 * GigaEthernet ports (1000BT or 1000BX - factory setting)
- ▶ 1 * RS232 console port (front or rear)
- ▶ 1 * rear USB 3.0 ports
- ▶ 2 * rear USB 2.0 ports
- ▶ 4 * rear SATA interfaces
- ▶ GPIOs

Extension

- ▶ 1 * **FPGA Kintex-7**
 - 1 RS232/RS422 serial port (rear)
 - GPIOs (X8d - on P2)
 - Optional video interface (VGA frame buffer)
- ▶ 1 * **XMC slot** PCIe x8 -or 2 * x4 (Option, with restriction - consult us)

Miscellaneous

- ▶ Status Leds
- ▶ PIC µ-controller for System Management (VITA 46.11)

Accessories

- ▶ Engineering kit for debug : JTAG/COP, console,...
- ▶ 3U Rear Transition Module

The **IC-INT-VPX3d/e** is a 3U VPX board compliant with VITA 46.0 standard. It is available in air-cooled and conduction cooled versions.

IC-INT-VPX3d/e

Intel® XEON (Broadwell-DE SoC) SBC

Boot Loader

Interface Concept Single Board Computers based on Intel CPUs use the new UEFI firmware technology. This Boot Loader, **developed and tested by IC R&D team**, implements all the initializations and optimized PBITs while ensuring the shortest boot time before launching the UEFI shell or loading the Operating System from storage devices (CD, DVD, HDD, USB...) or network.

When the final application is running, Runtime services remain in memory allowing thus the user to access UEFI variables for monitoring (e.g. PBIT results) or setup operations.

On request, IC can even customize the Boot Loader to keep only what is strictly necessary for customer's applications.

OS support

Interface Concept provides LSP Linux® distributions (IC SDK, others...). For VxWorks® and Windows, please consult us.

Multiware

In order to empower customers to concentrate their efforts on their most valuable tasks, Interface Concept has developed a Fabric Management Software implementing optimized services between PCIe domains over non transparent bridges (NTB) such as: DMA transfers, Ethernet emulation over PCIe, management of shared memory, messages and semaphores, etc.

Interface features

Front connectors (air cooled versions)

- ▶ mini USB console port
- ▶ HDMI connector (option)
- ▶ USB2 connector (option)

P1 connector

IC-INT-VPX3d

- ▶ 2 * 10GigaEthernet ports available either as: 2*10G KX4or 2*10G KR (factory setting)
- ▶ 1 * PCIe x4 port (supporting NTB)

IC-INT-VPX3e

- ▶ 2 * PCIe x4 ports (NT/RC, mergeable as 1 * NT x8)
- ▶ 2 * 10GigaEthernet ports (2*10G KR)

- ▶ 2 * GigaEthernet ports available either as: 2*1000BT or 2*1000KX (factory setting)
- ▶ 1 * Console port

P2 connector

- ▶ USB3 port
- ▶ USB2 ports
- ▶ SATA ports
- ▶ PCIe x4 (supporting 4 * x1)
- ▶ GPIOs
- ▶ console port
- ▶ RS232/RS422 serial port

Block Diagram *OpenVPX*

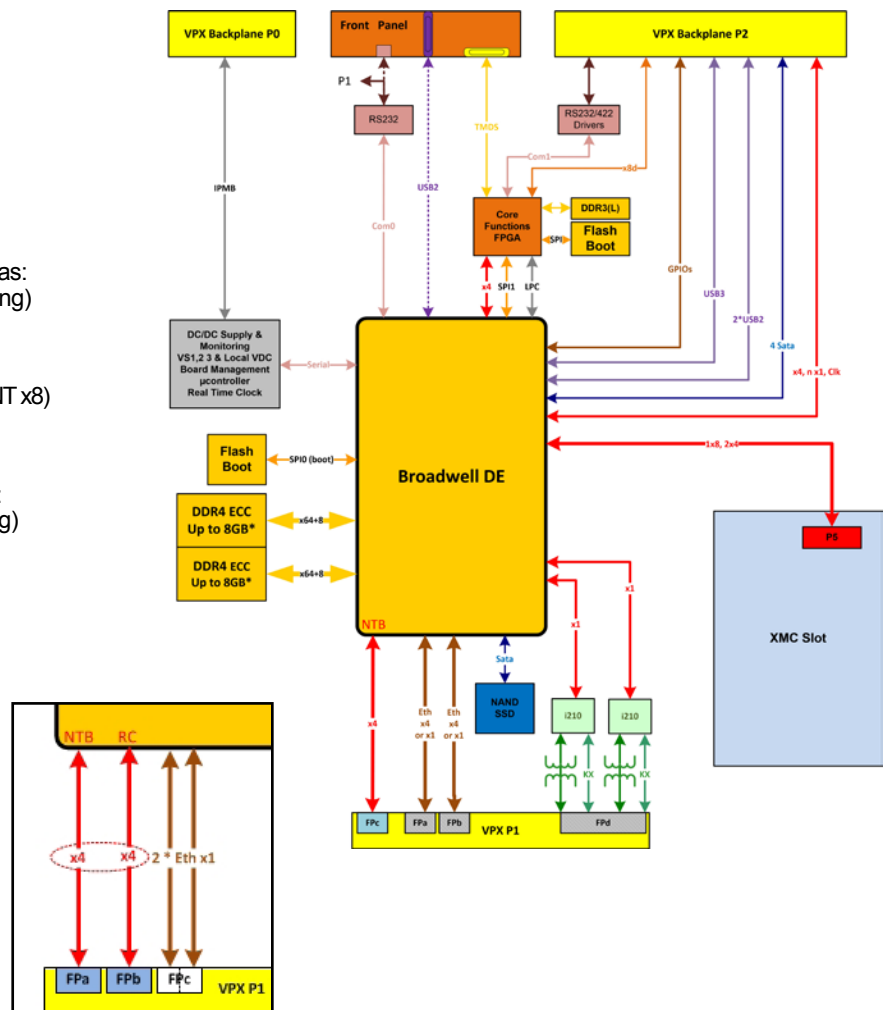

IC-INT-VPX3e

IC-INT-VPX3d

Environmental Specifications:

Please consult the IC-INT-VPX3d/e page at www.interfaceconcept.com.

Ordering Information:

Please contact our sales department : tel. +33 (0)2 98 57 30 30 - email : info@interfaceconcept.com

This document supersedes any earlier documentation relating to the products referred to herein. The information contained in this document is current at the date of publication. It may subsequently be updated or withdrawn without notice.

