

K7

8 Safe Digital Outputs, Low-Side Switching menTCS Safe I/O Board SIL 2 to SIL 4

- » 8 digital outputs, 24 V, 48 V, 72 V, 96 V, 110 V
- » 300 mA per channel
- » Low-side switch outputs (load to supply voltage)
- » Optical isolation from other cards
- » Fail-safe board architecture
- » Certifiable up to SIL 4 (with report from TÜV SÜD)
- » Developed according to EN 50129, EN 50128 and IEC 61508
- » Extensive supervision functions
- » Full EN 50155 compliance
- » -40 to +85°C qualified
- » Conformal coating



Digital Outputs for menTCS

The K7 is a safe digital output card for use in a modular MEN Train Control System. menTCS is a platform to perform safe train control functions, focusing on rolling stock applications like Automated Train Operation (ATO) or Automated Train Protection (ATP). It usually consists of the **MH50C menTCS controller system** and safe remote I/O boxes, e.g., **KT8**. The K7 can be a part in any of these systems, with one card providing 8 digital outputs.

Safe, Certified Railway I/O

Developed according to EN 50129/EN 50128, K7 boards can be used for SIL 1, SIL 2, SIL 3 and SIL 4 applications. All menTCS I/O components come with dedicated SIL 4 certification packages from TÜV SÜD, reducing the integrator's certification effort and risk, and resulting in lower integration costs.

Functional Safety Design

With a dedicated onboard supervisor and FSoE features (Fail Safe over Ethernet), the I/O board is equipped with all the mechanisms required to provide protection in functionally safe systems. The I/O card reacts to be fail-safe: it enters the safe state if it detects an error.

In-System Connection using Real-Time Ethernet

menTCS I/O boards are physically shorter than a 3U CompactPCI board. Inside a menTCS system, these cards connect to the backplane using an extension. This links them to the menTCS EBUS, power supply, and address lines, allowing safe real-time Ethernet communication within the system.

Front I/O is connected via spring cage terminal blocks for fast installation thanks to reduced wiring.

EN 50155 Rolling Stock Compliance

The K7 supports the voltage ranges defined by EN 50155 for railway applications. Being usable in all types of different trains optimizes the I/O board's interoperability. Its operating temperature complies with the class TX specifications of -40 to +70 °C (10 minutes up to +85 °C). Standard boards include conformal coating.

Along with its full EN 50155 compliance and long-term availability of a minimum 10 years, the K7 is a rail-ready I/O component.

Safe Software Concept

All menTCS components are supported by certified QNX BSP and driver software.

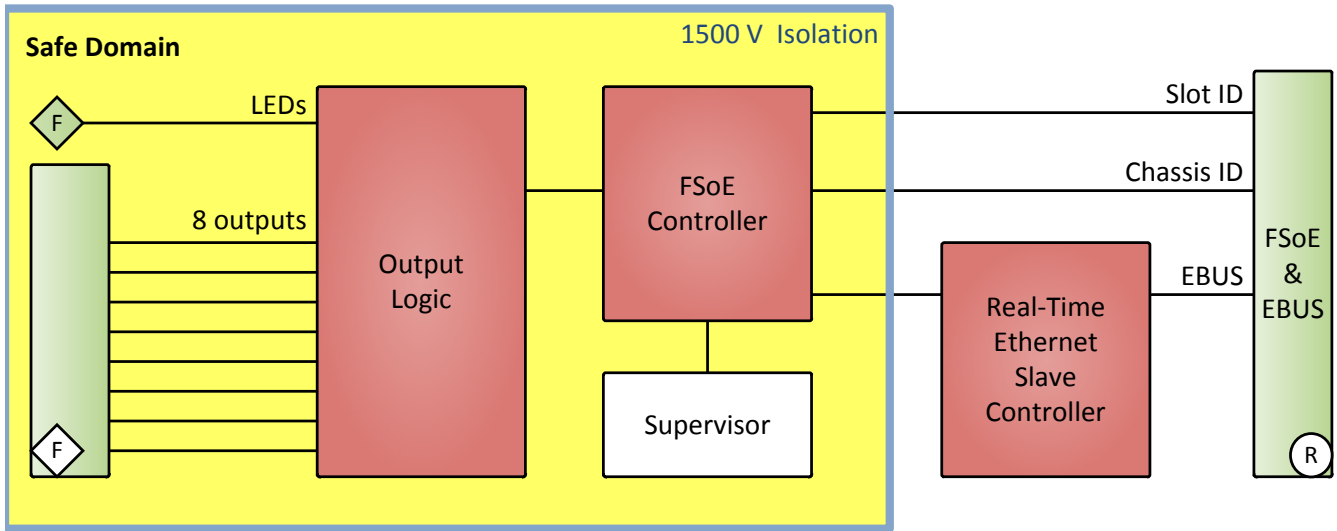

◇ F Front ○ R Rear

Digital Outputs

- Output voltage
 - 24 V, 48 V, 72 V, 96 V, 110 V nom. (EN 50155)
- Output current
 - 300 mA per channel max.
- Output type
 - Low-side switch outputs (load to supply voltage)

Front Interfaces

- Digital I/O
 - One spring cage terminal block
 - Eight output channels
- Status LEDs
 - Binary channel status, one LED per channel
 - I/O error
 - FSoE activity
 - Real-time Ethernet error
 - Real-time Ethernet state indication

Rear Interfaces

- EBUS
 - Two real-time Ethernet channels, ETG.1000
- menTCS FSoE
 - Slot ID and chassis ID for unique FSoE address

Supervision and Control

- Safe supervisor
 - Check for overvoltage, undervoltage, excess temperature
 - Watchdog
 - Monitor self-test

Backplane Standard

- ETG.1000 EBUS

Electrical Specifications

- Supply voltage
 - +12 V (10.8 to 13.2 V)
- Isolation voltage
 - 1500 V AC

Mechanical Specifications

- Dimensions
 - 100 mm x 100 mm, 4 HP

Environmental Specifications

- Classification for railway applications
 - EN 50155: Rolling stock, vehicle body
- Temperature range (operation)
 - -40°C to +85°C (qualified components) (EN 50155, class TX)
- Temperature range (storage): -40°C to +85°C
- Cooling concept
 - Air-cooled, natural convection
- Humidity
 - EN 50155: Rolling stock, vehicle body
- Vibration/Shock
 - EN 50155: Rolling stock, vehicle body class B
- Altitude: -300 m to +3000 m
- Conformal coating

Safety

- Functional Safety
 - Certifiable to SIL 2, SIL 3 or SIL 4 according to EN 50129 ("safety case" document and certificate from TÜV SÜD)
 - Hazard rate (THR) for safety functions $\leq 1E-8 / h$
 - Board maintains safe state after a failure
- Electrical Safety
 - EN 50155: Rolling stock, vehicle body
- Flammability
 - UL 94V-0
- Fire Protection
 - EN 45545

EMC

- EN 50155: Rolling stock, vehicle body

Software Support

- PACY (Process Data Framework for Cyclic Applications)
- QNX
- **For more information on supported operating system versions and drivers see Software.**

Germany

MEN Mikro Elektronik GmbH

Neuwieder Straße 3-7
90411 Nuremberg
Phone +49-911-99 33 5-0

sales@men.de
www.men.de

USA

MEN Micro Inc.

860 Penllyn Blue Bell Pike
Blue Bell, PA 19422
Phone 215-542-9575

sales@menmicro.com
www.menmicro.com

France

MEN Mikro Elektronik SAS

18, rue René Cassin
ZA de la Châtelaine
74240 Gaillard
Phone +33-450-955-312

sales@men-france.fr
www.men-france.fr

China

MEN Mikro Elektronik (Shanghai) Co., Ltd.

Room 808-809, Jiaxing Mansion, No. 877 Dongfang Road
200122 Shanghai
Phone +86-21-5058-0961

sales@men-china.cn
www.men-china.cn

Up-to-date information, documentation and ordering information:

www.men.de/products/k7/

The date of issue stated in this data sheet refers to the Technical Data only. Changes in ordering information given herein do not affect the date of issue. All brand or product names are trademarks or registered trademarks of their respective holders.

MEN is not responsible for the results of any actions taken on the basis of information in the publication, nor for any error in or omission from the publication.

MEN expressly disclaims all and any liability and responsibility to any person, whether a reader of the publication or not, in respect of anything, and of the consequences of anything, done or omitted to be done by any such person in reliance, whether wholly or partially, on the whole or any part of the contents of the publication.

The correct function of MEN products in mission-critical and life-critical applications is limited to the environmental specification given for each product in the technical user manual. The correct function of MEN products under extended environmental conditions is limited to the individual requirement specification and subsequent validation documents for each product for the applicable use case and has to be agreed upon in writing by MEN and the customer. Should the customer purchase or use MEN products for any unintended or unauthorized application, the customer shall indemnify and hold MEN and its officers, employees, subsidiaries, affiliates, and distributors harmless against all claims, costs, damages, and expenses, and reasonable attorney fees arising out of, directly or indirectly, any claim or personal injury or death associated with such unintended or unauthorized use, even if such claim alleges that MEN was negligent regarding the design or manufacture of the part.

In no case is MEN liable for the correct function of the technical installation where MEN products are a part of.

© 2016 MEN Holding