

D3B - 6U CompactPCI® MPC8245 SBC / M-Module™



- PowerPC® MPC8245 with 603e core
- 1-slot CompactPCI® system slot
- 512 MB DRAM, CompactFlash®
- Dual Fast Ethernet
- 4 COMs, USB, IDE, keyboard/mouse
- 3 M-Module™ slots
- MENMON™ BIOS for PowerPC® cards

The D3 is a single-board computer for embedded applications based on the MPC 8245 PowerPC®. It can be used in a CompactPCI® system slot or as a stand-alone card.

The D3 comes with the MPC8245 PowerPC® with 300MHz clock frequency and a local 32-bit/33-MHz PCI data bus. It is a complete state-of-the-art SBC offering DRAM, Flash and CompactFlash® memory, dual Fast Ethernet, 4 COMs, USB, IDE and keyboard/mouse interfaces as well as an optional onboard hard disk.

In addition, the D3B CPU board can be equipped with M-Module™ mezzanine cards. M-Modules™ are

recommended for real-world I/O like analog/binary process I/O and instrumentation I/O. The modular combination of I/O functionality on a single-board computer allows to build up tailored control systems which appear as customized solutions based on standard components.

Depending on the kind of I/O requirements, further standard versions of D3 are available for other mezzanine standards.

The D3 comes with MENMON™ support. MENMON™ is a sort of BIOS which can be used for bootstrapping operating systems (from disk, flash or network), for hardware testing, or for debugging applications without running any operating system.

Technical Data

CPU

- PowerPC®
 - MPC8245
 - 300MHz
 - Double precision FPU

Memory

- L1 Cache integrated in MPC8245
- Up to 512MB SDRAM system memory
 - One 144-pin SO-DIMM slot for SDRAM modules
 - 100MHz memory bus frequency
- 2MB Flash
- Serial EEPROM 2KB for factory settings
- CompactFlash® card interface
 - Via onboard IDE
 - Type I
 - True IDE

Mass Storage

- IDE port for hard disk drives
 - Drive can be connected via ribbon cable or mounted directly on the CPU board using MEN adapter kit
 - Only one CompactPCI® bus slot needed even with hard disk
- One IDE port for local CompactFlash®

I/O

- USB
 - One USB 1.1 port
 - Available via I/O connector
 - External PHY
 - Data rates up to 12Mbits/s
- Ethernet
 - Two 10/100Base-T Ethernet channels
 - RJ45 connector at front panel with two LEDs
- One RS232 UART (COM1)
 - RJ45 connector at front panel
 - 16-byte transmit/receive buffer
 - Handshake lines: CTS, RTS; DCD, DSR, DTR
- One UART (COM2)
 - Accessible via I/O connector
 - Physical interface using SA-Adapter™ via 10-pin ribbon cable on I/O connector
 - RS232..RS485, isolated or not: for free use in system (e. g. cable to front)
 - 16-byte transmit/receive buffer
 - Handshake lines: CTS, RTS; DCD, DSR, DTR; RI
- Two UARTs (COM3/COM4)
 - Accessible via I/O connector
 - Physical interface using SA-Adapter™ via 10-pin ribbon cable on I/O connector
 - RS232..RS485, isolated or not: for free use in system (e. g. cable to front)
 - Handshake lines: none
- Keyboard/mouse
 - PS/2 compatible
 - External adapters for line drivers required

Mezzanine Slots

- Three M-Module™ slots
 - Compliant with M-Module™ standard
 - Characteristics: D16, D32, A08, A24, INTA, INTC

Miscellaneous

- Serial real-time clock with integrated 56-byte NVRAM
- Serial hardware watchdog in supervisory circuit
- Temperature sensor
- User LEDs (external)
- Hex switch for user settings

Local PCI Bus

- 32-bit/33-MHz, 3.3V V(I/O)
- Compliant with PCI Specification 2.2

CompactPCI® Bus

- Compliance with CompactPCI® Core Specification PICMG 2.0 R3.0
- System slot
- 32-bit/33-MHz PCI-to-PCI bridge
- V(I/O): +3.3V (+5V tolerant)

Electrical Specifications

- Supply voltage/power consumption:
 - +5V (-3%/+5%), 1.65A typ.
 - ±12V for mezzanines only, tbd.
- MTBF: 63,000h @ 50°C (derived from MIL-HDBK-217F)

Mechanical Specifications

- Dimensions: standard double Eurocard, 233.3mm x 160mm
- Weight (without mezzanines and accessories): 315g

Environmental Specifications

- Temperature range (operation):
 - 0..+60°C or -40..+85°C
 - Airflow: min. 10m³/h
- Temperature range (storage): -40..+85°C
- Relative humidity (operation): max. 95% non-condensing
- Relative humidity (storage): max. 95% non-condensing
- Altitude: -300m to + 3,000m
- Shock: 15g/11ms
- Bump: 10g/16ms
- Vibration (sinusoidal): 2g/10..150Hz
- Conformal coating on request

Safety

- PCB manufactured with a flammability rating of 94V-0 by UL recognized manufacturers

Technical Data

EMC

- Tested according to EN 55022 (radio disturbance), IEC1000-4-2 (ESD) and IEC1000-4-4 (burst)

Software Support

- MENMON™
- Linux
- VxWorks®
- QNX®
- OS-9®
- For more information on supported operating system versions and drivers see Software.

Diagram

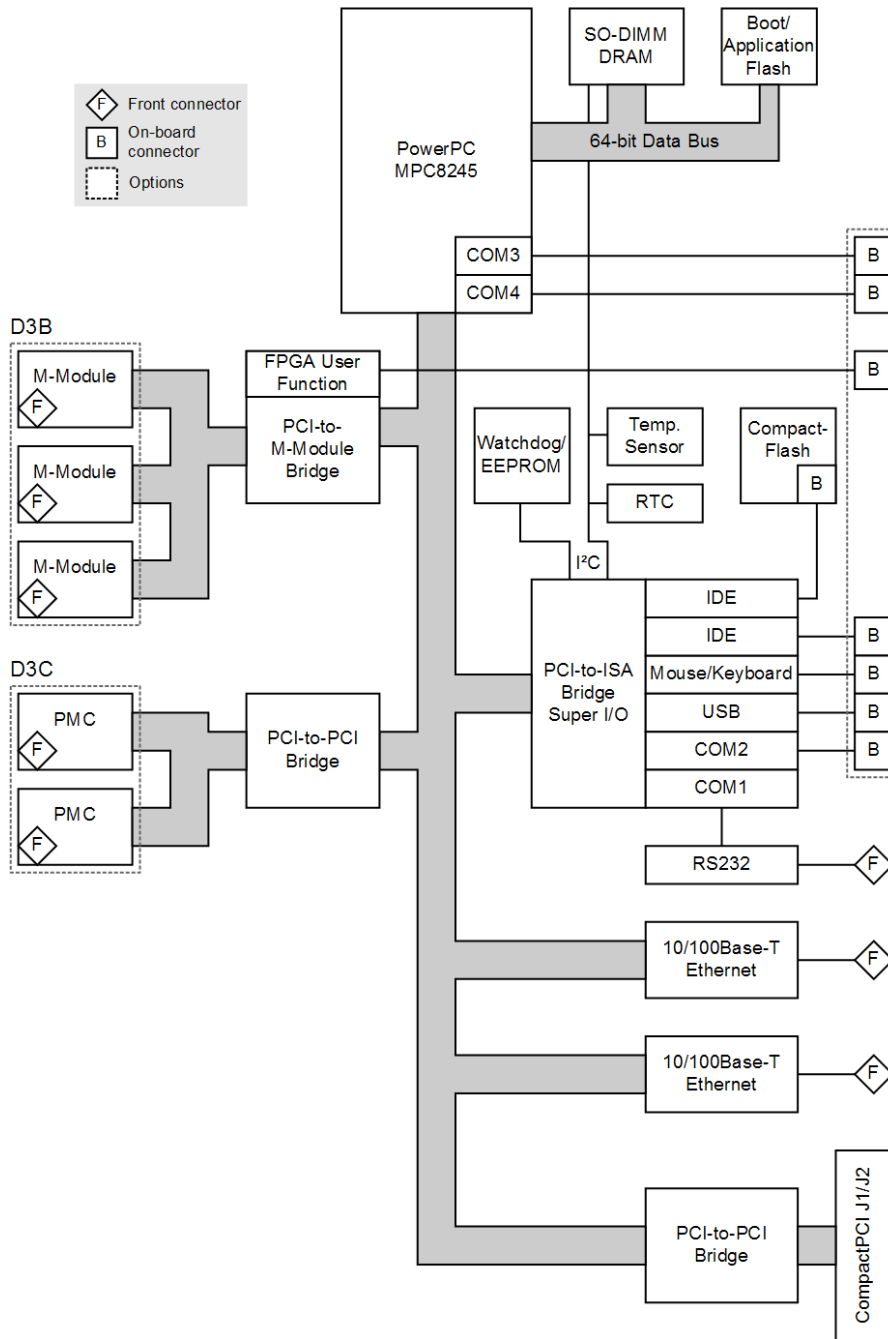

Configuration & Options

Standard Configurations

Article No.	CPU Type	Clock	System RAM	CFlash	Boot Flash	Mezzanine Slots	Operation Temperature
02D003A00	MPC8245	300 MHz	0 MB	0 MB	2 MB	3 PC-MIP®	0..+60°C
02D003A01	MPC8245	300 MHz	0 MB	0 MB	2 MB	3 PC-MIP®	-40..+85°C
02D003B00	MPC8245	300 MHz	0 MB	0 MB	2 MB	3 M-Modules™	0..+60°C
02D003B01	MPC8245	300 MHz	0 MB	0 MB	2 MB	3 M-Modules™	-40..+85°C
02D003C00	MPC8245	300 MHz	0 MB	0 MB	2 MB	2 PMC	0..+60°C
02D003C01	MPC8245	300 MHz	0 MB	0 MB	2 MB	2 PMC	-40..+85°C

Options

CPU

- MPC8245, 300 MHz

Memory

- System RAM
 - 64 MB, 128 MB, 256 MB or 512 MB
- CompactFlash®
 - 0 MB up to maximum available
- Boot Flash
 - 2 MB

SA-Adapters™

- Up to three SA-Adapters™ for UART functions (COM2..COM4)
- RS232, RS422, RS485

Mezzanine Slots

- 2 PMC
- 3 PC-MIP®
- 3 M-Modules™

Operation Temperature

- 0..+60°C
- -40..+85°C

Please note that some of these options may only be available for large volumes. Please ask our sales staff for more information.

Ordering Information

Standard Hardware

02D003B00	MPC8245/300MHz, 2MB Flash, 3 M-Module slots, 0..+60°C
02D003C00	MPC8245/300MHz, 2MB Flash, 2 PMC slots, 0..+60°C
02D003C01	MPC8245/300MHz, 2MB Flash, 2 PMC slots, -40..+85°C screened

Memory

0751-0023	CompactFlash card, 2 GB, Type I, -40..+85°C, fixed bit set
0751-0025	CompactFlash card, 512 MB, Type I, -40..+85°C, removable
0751-0026	CompactFlash card, 256 MB, Type I, -40..+85°C, removable
0751-0027	CompactFlash card, 1 GB, Type I, -40..+85°C, fixed bit set
0751-0031	CompactFlash card, 4 GB, Type I, -40..+85°C, fixed bit set
0751-0032	CompactFlash card, 8 GB, Type I, -40..+85°C, fixed bit set
0752-0048	64MB DRAM 0..+60°C for 02D003x00
0752-0049	128MB DRAM 0..+60°C for 02D003x00
0752-0050	256MB DRAM 0..+60°C for 02D003x00
0752-0132	512MB DRAM -40..+85°C for 02D003x01

SA-Adapters

08SA01-00	RS232, not optically isolated, 0..+60°C
08SA02-00	RS422/485, half duplex, optically isolated, 0..+60°C
08SA02-01	RS422/485, full duplex, optically isolated, 0..+60°C
08SA02-07	RS422/485, full duplex, optically isolated, -40..+85°C screened
08SA03-00	RS232, optically isolated, 0..+60°C
08SA03-01	RS232, optically isolated, -40..+85°C screened

Systems & Card Cages

0701-0030	CompactPCI 19" 3U/84HP rack-mount enclosure for 6U cards (horizontal), 6-slot backplane, system slot left, 250W ATX wide-range PSU, 2 fans, prepared for rear I/O
------------------	---

Miscellaneous

05A012-00	Mounting kit for 2.5" hard disk (9.5mm adapter) for A12, D3, SC13
05A012-01	Mounting kit for 2 SA adapters for A12/A15/D3, incl. 6U 1-slot VME or CompactPCI front panel incl. ribbon cable, without SA adapters
05AD67-00	IDE mounting kit 44-pin to 44-pin; 50.8 mm; installation kit for Kahlua Box or A12, A15, D3 with AD67, temperature range: -40..+85°C
05F006-00	RS232 interface cable RJ45 to 9-pin D-Sub (1 COM to 1 COM), 2m
05M000-17	25 mounting screw sets to fix M-Modules on carrier boards
0710-0028	Industrial PATA hard disk, 2.5", 80GB, 24hours/7days, for on-board mounting (hard disk mounting kit may be required additionally), -30..+85°C qualified
08AD67-01	I/O extension 19" 6U 4HP incl. 1 USB connector, 1 keyboard connector, 1 mouse connector; prepared for 3 SA adapters, prepared for HDD 2.5", reset, abort, 0..+60°C

Software: VxWorks

10F001N60	VxWorks BSP (MEN) for A15, F1N, B11, A12, D3, SC13 and Kahlua Box
------------------	---

Software: QNX

10F001N40	QNX BSP (MEN) for F1N, B11, A12, A15, D3, SC13 and Kahlua Box
------------------	---

Software: OS-9

10F001N01	OS-9(000) V.2.2/3.x BSP (object code, MEN) for F1N, B11, A12, D3, SC13 and Kahlua Box
10F001N02	OS-9(000) V4.2 BSP (object code, MEN) for F1N, B11, A12, A15, D3, SC13 and Kahlua Box

Software: Firmware/BIOS

14A012-00	MENMON (Firmware) for A12, D3 and SC13 (object code)
------------------	--

Ordering Information

Documentation

20D003-00 D3 User Manual

21MENM-00 MENMON 2nd Edition User Manual

For the most up-to-date ordering information and direct links to other data sheets and downloads, see the D3B online data sheet under » www.men.de.

Germany

MEN Mikro Elektronik GmbH
Neuwieder Straße 5-7
90411 Nuremberg
Phone +49-911-99 33 5-0
Fax +49-911-99 33 5-901
E-mail info@men.de
www.men.de

France

MEN Mikro Elektronik SA
18, rue René Cassin
ZA de la Châtelaine
74240 Gaillard
Phone +33 (0) 450-955-312
Fax +33 (0) 450-955-211
E-mail info@men-france.fr
www.men-france.fr

USA

MEN Micro, Inc.
24 North Main Street
Ambler, PA 19002
Phone (215) 542-9575
Fax (215) 542-9577
E-mail sales@menmicro.com
www.menmicro.com

The date of issue stated in this data sheet refers to the Technical Data only. Changes in ordering information given herein do not affect the date of issue.

All brand or product names are trademarks or registered trademarks of their respective holders.

Information in this document has been carefully checked and is believed to be accurate as of the date of publication; however, no responsibility is assumed for inaccuracies. MEN Mikro Elektronik accepts no liability for consequential or incidental damages arising from the use of its products and reserves the right to make changes on the products herein without notice to improve reliability, function or design. MEN Mikro Elektronik does not assume any liability arising out of the application or use of the products described in this document.

The products of MEN Mikro Elektronik are not suited for use in nuclear reactors or for application in medical appliances used for therapeutical purposes.

Application of MEN's products in such plants is only possible after the user has precisely specified the operation environment and after MEN Mikro Elektronik has consequently adapted and released the product.

Copyright © 2009 MEN Mikro Elektronik GmbH. All rights reserved.