

12 or 24 Gigabit Ethernet ports with full wire speed switching capability up to 37Mpps.

### Description

**T4000a** is built on the latest generation of Gigabit switch engine and PHY transceiver. It combines a layer 2+ switch and a full layer 3 router with an optimized power consumption. Eight levels of queue priority combined with QoS policy makes tuning easy for critical delay-sensitive applications.

**T4000a** ports are compatible both with VME or cPCI system. It is designed to optimize the integration of Gigabit switched networks. Twelve front Gigabit ethernet ports are implemented on the one slot version, twelve additional ports are available on the two slot configuration.

The **T4000a** can be configured for a combination of 10/100/1000BT or Fiber ports. Several types of optical interfaces are available 1000SX, 1000LX, WDM mode.

Auto-crossover, auto-polarity, auto-negotiation and automatic MAC address management make the **T4000a** a true Plug & Play switch. The Marvell Virtual Cable tester allows remote identification of potential cable malfunctions such as excessive pair skew, cable opens, impedance mismatch. This switch is fully compatible with the T4020a, T4030a and T4050a range.

### Management Capabilities

The **T4000a** can be monitored from a browser, a remote application via UDP or SNMP allowing ease of system management. A comprehensive built-in test allows easier switch maintenance. Many additional functions are provided on this full-managed version:

- Configuration of all the PHY and switch parameters: ports monitoring, static MAC address, QoS policy, Multicast and VLAN control, STP/RSTP protocols, MAC security
- Monitoring of all statistical counters and an extensive list of RMON counters

Switchware software provides layer 3 functions, allowing local IP forwarding (IPv4/ IPv6), static and dynamic protocols (RIP, OSPF) routing, proxy-ARP and DHCP-relay. These layer 3 functions are managed through a CLI interface. The IP routing and the layer 3 protocols are carried out by the processor and the forwarding is carried out by a full speed layer 3 engine router running at wire speed. **T4000a** can be used as an open switching platform to implement specific functions.

### Flexible Configurations

Its 6U form factor allows the **T4000a** to be integrated in VME 32 or 64x, cPCI 6U or stand-alone applications. **T4000a** is available from standard to rugged grade.

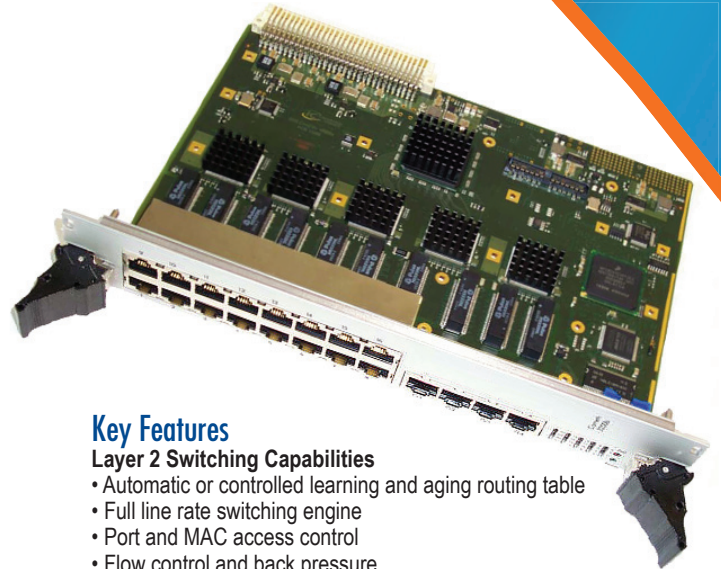

### Key Features

#### Layer 2 Switching Capabilities

- Automatic or controlled learning and aging routing table
- Full line rate switching engine
- Port and MAC access control
- Flow control and back pressure
- 9KB jumbo frames
- IPV4 IGMP IPV6 MLD snooping
- MAC address transplant for rapid reconfiguration 802.1W
- Link aggregation – static or LACP
- Bandwidth management
  - o Flow rate limiting
  - o Egress rate shaping
  - o Minimal bandwidth guarantee per traffic class
- VLAN Services
  - o 4K active VLAN
  - o 4K bridge multicast groups
  - o Flexible VLAN assignment 802.1Q
    - port based, protocol based 802.1V, service VLANs 802.1ad, policy based VLANs
- Quality of Service engine
  - o Eight priority queues per port
  - o Traffic class assignment per 802.1p tag, MAC address, port, DiffServ, CP or policy engine
- Layer 3 IP V4 and V6 routing engine
  - o 1K UC ARP entries
    - RIP V2, OSPF, V2 routing
    - Proxy ARP
    - DHCP relay
    - IGMP server
- Security features
  - o 802.1x port authentication
  - o Multicast / broadcast limiting
  - o STP / RSTP protocol
  - o Virtual cable tester on line
- Flexible management tools
  - o Web or CLI management
  - o Standard and private MIBS
  - o Enhanced port mirroring



Modular Storage



# T4000a

## Main Features

### Physical Layer

- 10/100/1000Mbs ports.  
Auto-Negotiation with Downshift.  
Automatic MDI/MDIX crossover for all 3 speeds of operation.  
Automatic polarity correction.  
Online virtual cable tester.
- 1000SX transceivers with:  
LC-duplex connectors 850nm source  
Maximum link lengths : 275m for 62.5/125µm MM fiber  
or 50m for 50/125µm fiber
- 1000LX transceivers with:  
LC-duplex connectors 1300nm source  
Maximum link lengths : 550m for 62.5/125µm MM fiber  
Automatic or 10 Km for 8/125µm SM fiber polarity correction

### Layer 2 switching

802.1D/Q compliant with a full-line rate Ethernet switching engine 16000 MAC address database.  
Automatic or controlled aging and learning mechanism.  
Tag extraction and insertion (802.1p), Jumbo frames up to 9KBytes.  
Back pressure for half-duplex, IEEE802.3x for full duplex.  
Discard broadcasts above critical threshold.  
Link aggregation with static or dynamic LACP IGMP & MLD snooping.

### VLAN

Supports Layer 2 partitioning of up to 4000 VLANs 802.1Q (256 active)  
VLAN is flexibly programmed to any value from 1 to 4094 Protocol-based VLAN (802.1v) or Port-based VLAN (802.1v).

### Security

Port and MAC access control compliant with 802.1X authentication.

### Layer 3 Switching / Routing

Non-blocking Router engine running at full wire speed.  
Eight queue levels per port.  
Minimal and maximal bandwidth per traffic class using weighted round robin and strict priority scheduling.  
72 quality of service profiles for traffic class drop precedence.

### Layer 3 services

IGMP server  
RIP V2  
OSPF V2  
UDP relay  
STP/RSTP provides redundant link support.

### Front panel LEDs

Power supply and switch status  
Switched ports: activity & link

### cPCI

3.3 VDC Power Supply only

### VME

5 VDC Power Supply only

### Power supply

Pest= 30W (full configuration)

### Switch Management

Onboard firmware is implemented with comprehensive built-in test (loop back mode used during diagnostics), maintenance functions and network (BootP) updating functions. Management software provides a wide range of configuration Layer 2 / 3 functions on any port: transmission speed/mode, VLAN, STP parameters, mirroring, QoS, etc.  
MIB, RMON counters and private information retrievable via SNMP agent, web-browser and CLI for Layer 3 functions.  
Management via Switchware, a Linux application package running on the resident PowerPC Processor.

## Standards Compliance

### Emissions

EN55022 Class A

### Immunity

CEI 6000-4-2 (ESD), 6000-4-3 (Electric field), 6000-4-4 (Burst), 6000-4-5 (Surge).

### MTBF

TBD

### Security

EN60950

## Block Diagram

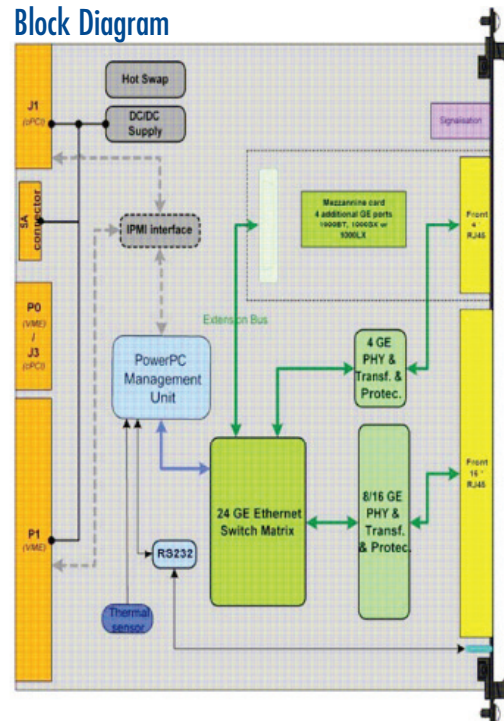

## Environmental Specifications

Criterion	Standard Grade	Extended Grade	Rugged Grade	CC Grade
Conformal Coating	Optional	Standard	Standard	Standard
Operating Temp.	0 to 55°C	-20 to 65°C	-40 to 75°C	-40 to 75°C
Humidity - non cond.	5 to 90%	5 to 95%	5 to 95%	5 to 95%
Storage Temp.	-45 to 85°C	-45 to 85°C	-45 to 100°C	-45 to 100°C
Sinusoidal Vibration	2G [20..2000]Hz	2G [20..2000]Hz	5G [20..2000]Hz	5G [20..2000]Hz
Random Vibration	0.002g <sup>2</sup> /Hz [10..2000]Hz	0.002g <sup>2</sup> /Hz [10..2000]Hz	0.05g <sup>2</sup> /Hz [10..2000]Hz	0.1g <sup>2</sup> /Hz [10..2000]Hz
Shock 1/2Sin. 11ms	20G	20G	40G	40G

## Ordering Information

Please contact our sales department at (215) 956-1200 or via email at [sales@elma.com](mailto:sales@elma.com).



ACT/Technico logo and brand of products are registered trademarks of Elma Electronic Inc.

**ELMA**  
Your Solution Partner