

# Themis RES-32s Server



## Themis' Rugged, Rackmountable, 3RU Dual UltraSPARC IIIi Server

Themis Computer's new RES-32s™ dual-processor server delivers the robust design features of Themis' Rugged Enterprise Server (RES) family in an efficient, three rack unit (3RU) chassis. The RES-32s is a high performance dual SMP system design, ideal for use in mission critical applications. Combining the Sun Blade™ 2500 design with Themis' proprietary thermal and mechanical design techniques, the RES-32s is distinguished by its ruggedized design, reliable operation in high shock and vibration environments, and six 64-bit PCI slots.

### UltraSPARC IIIi based for high performance and reliability

Featuring the Sun Microsystems™ 1.28GHz UltraSPARC® IIIi processor, Themis' RES-32s provides OEMs and systems integrators a space efficient server ready for fast integration into mission-critical applications. Designed for deployment in demanding environments, the RES-32s can withstand shock loads of 25G. The RES-32s flexible design provides six vertical PCI slots, two hot swappable SCSI drives, CD-RW/DVD drive, and an optional DDS tape. Themis' new RES-32s supports either a Sun XVR-100 graphics adaptor, XVR-600 graphics adaptor or a XVR-1200 high performance graphics card, enabling the system to provide outstanding 3-D graphics performance.

The system's modular design allows users versatile configurability and system expansion. The RES-32s is easily expanded through the addition of Sun® or other commercially available, off the shelf networking cards, I/O, peripherals and other value-added options to meet current and future system requirements.

### Themis RES-32s Features

- Dual-processor Sun UltraSPARC IIIi server
- 1.28GHz UltraSPARC IIIi processors with 1MB L2 cache
- Rackmountable Sun Blade 2500 design
- Up to 4GB of DDR266 SDRAM memory per processor
- 1 or 2 removable SCSI Hard Disk Drives, up to 146GB each
- HDD/CD-RW/DVD storage options
- Supports optional FC-AL Sun StorEdge™ MultiPack
- Optional InfiniBand ports for TPX-4 connectivity
- Designed for reliability in extended operating environments
- Temperature/fan speed monitor
- Compact, rack-optimized design for space constrained environments
- Optional rackmount slides
- Shock: 25G @ 40msec (MIL-STD-901D)
- Operational range: 0° to 50° C
- Humidity: Up to 90% non-condensing
- Modular design for easy upgrade and service – all FRUs may be changed in < 30 minutes
- Sun Solaris™ 8 and 9<sup>1</sup> Operating Environment support

<sup>1</sup>Solaris 9 support after April 4, 2004

# RES-32s Motherboard Block Diagram

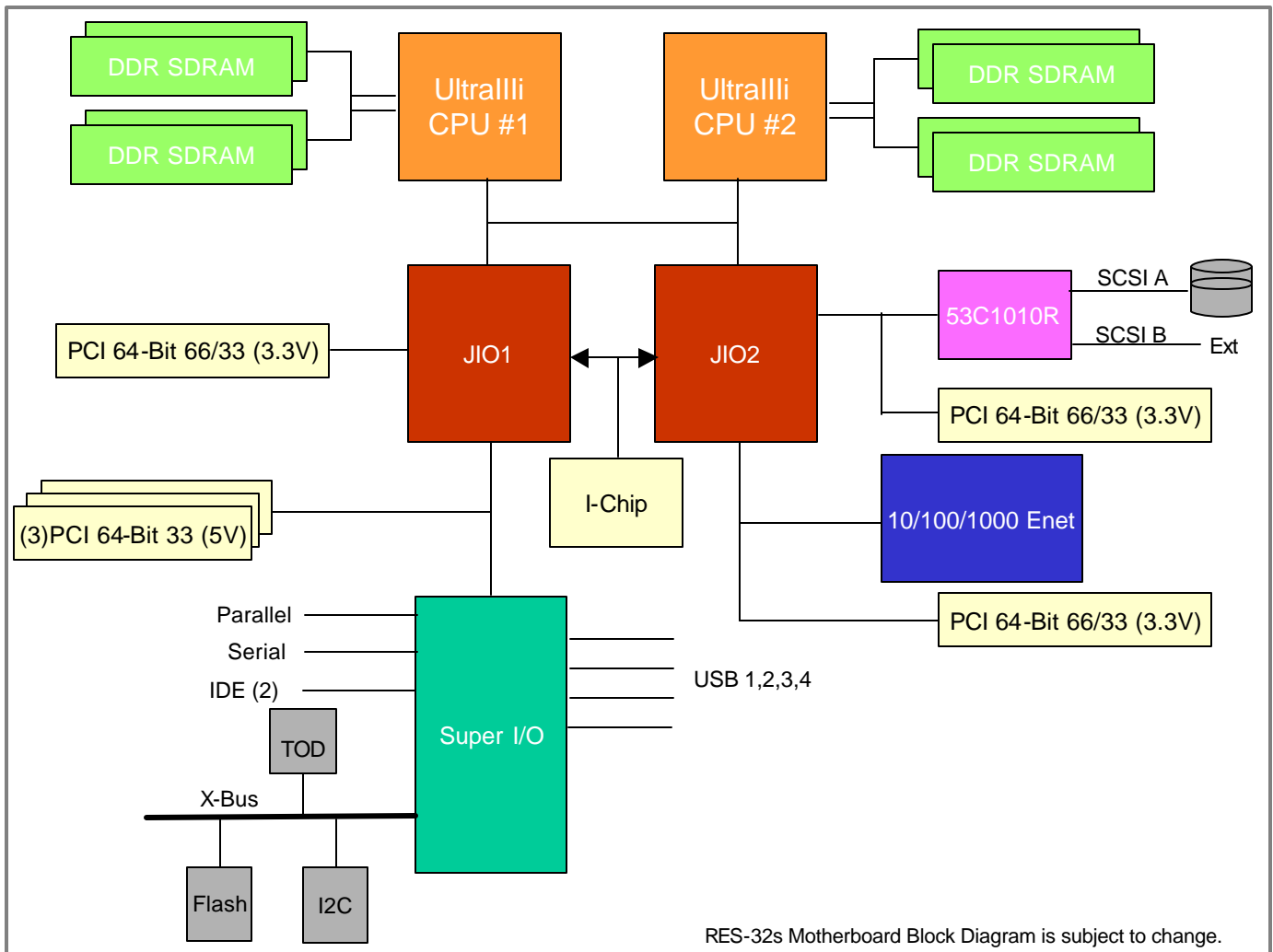

## RES-32s Specifications

- Single or dual 1.28GHz UltraSPARC IIIi processors
- Up to 8GB DDR266 SDRAM, ECC protected memory
- Rear panel access and I/O:
  - One (1) 10/100/1000-BaseT ports
  - One (1) RS-232 Serial port (DB9)
  - Four (4) USB ports
  - Six (6) full-length 64-bit PCI slots (3 64-bit/66MHz, 3 64-bit/33MHz)
  - Power connector and switch
  - Audio: Line-In / Line-Out / Microphone
  - One (1) Parallel port
  - One SCSI (Ultra160) port
- Supports Sun type 6 USB keyboard, Sun USB mouse
- Sun Solaris 8 and 9 Operating Environment support
- Rugged case and extruded aluminum chassis

### Front panel incorporates the following:

- Up to Two (2) Ultra160 SCSI drives Hard Disk Drives (up to 146GB per drive)
- CD-RW/DVD drive
- DAT Tape drive (optional)
- Status LEDs
- Airflow direction: Front to Rear
- Operating Shock: up to 25 G @ 40 ms
- Operating Temperature: 0 - 50°C
- Operating Humidity: up to 90% non-condensing
- Power Supply: Up to two, 110/220 VAC autoranging, N+1 hot swappable (50/60 or 400 Hz)
- Safety: UL 1950, CSA 950
- RFI/EMI: FCC Class B
- Dimensions (HWD): 3U (133 mm) x 17.1" (19") x 20.0" (508.0 mm)



**Themis Computer**  
 3185 Laurelview Court  
 Fremont, CA 94538  
 Tel: 510-252-0870  
 Fax: 510-490-5529  
 Email: [info@themis.com](mailto:info@themis.com)  
[www.themis.com](http://www.themis.com)

**Themis Computer European Sales Office**  
 5 rue Irène Joliot-Curie  
 38320 Eybens, France  
 Tel: +33.476.14.77.86  
 Fax: +33.476.14.77.89  
 Email: [europe\\_sales@themis.com](mailto:europe_sales@themis.com)

Themis, the Themis logo, Rugged Enterprise Server, and RES-32s are trademarks or registered trademarks of Themis Computer. Sun, Sun Microsystems, Sun Blade, the Sun logo, StorEdge, and Solaris are trademarks or registered trademarks of Sun Microsystems, Inc. in the United States and other countries. UltraSPARC, the ULTRASPARC Driven logo, and SPARC trademarks are used under license and are trademarks or registered trademarks of SPARC International, Inc. in the United States and other countries. Products bearing SPARC trademarks are based upon an architecture developed by Sun Microsystems, Inc.